

# Tutorials COMP3411/9814 20T1

## Week 3 Solutions

### Question 1 - The route-finding problem using the Romania map from Russell & Norvig

1. (Depth-first) Arad, Sibiu, Fagaras, Bucharest (note that the solution is found on the first branch only because of the rule for ordering the successors alphabetically; this is not usually the case!)
2. (Breadth-first) Arad, Sibiu, Timisoara, Zerind, Fagaras, Bucharest (assuming that the search stops once the goal state is generated and that when expanding a node, previously expanded nodes are checked to ensure that nodes with states already explored are not added to the frontier, e.g. Arad which is generated via the paths Arad → Sibiu → Arad and Arad → Sibiu → Oradea → Zerind → Arad)
3. (Uniform-cost) Arad (0), Zerind (75), Timisoara (118), Sibiu (140), Oradea (146), Rimnicu Vilcea (220), Lugoj (229), Fagaras (239), Mehadia (299), Pitesti (317), Craiova (366), Drobeta (374), Bucharest (418) (assuming a check that nodes with states previously generated are not added to the frontier, except when they have lower path cost than a node with that state already on the frontier, in which case the node with higher path cost is removed, so ignore Oradea (291) reached via Sibiu, and Sibiu (297) reached via Zerind and Oradea)
4. (Iterative deepening) Arad, Arad, Sibiu, Timisoara, Zerind, Arad, Sibiu, Fagaras, Oradea, Rimnicu Vilcea, Timisoara, Lugoj, Zerind, Oradea, Arad, Sibiu, Fagaras, Bucharest (assuming a cycle check on each path, so omit Arad reached via Arad → Sibiu → Arad)
5. (Greedy) Arad (366), Sibiu (253), Fagaras (178), Bucharest (0)
6. (A\*) Arad (366), Sibiu (393), Rimnicu Vilcea (413), Pitesti (415), Fagaras (417), Bucharest (418) (unexpanded states on the frontier are Timisoara (447), Zerind (449), Craiova (526), Oradea (671)) – for example,  $f(\text{Rimnicu Vilcea}) = g(\text{Rimnicu Vilcea}) + h(\text{Rimnicu Vilcea}) = 140 + 80 + 193 = 413$  (remember to use the total path cost from Arad to Rimnicu Vilcea here)

### Question 2

Fagaras (415) is expanded before Pitesti (417)

### Question 3 - Path Search Algorithms on a Graph

Consider the task of finding a path from start state S to goal state G, given the distances and heuristic values in this diagram:

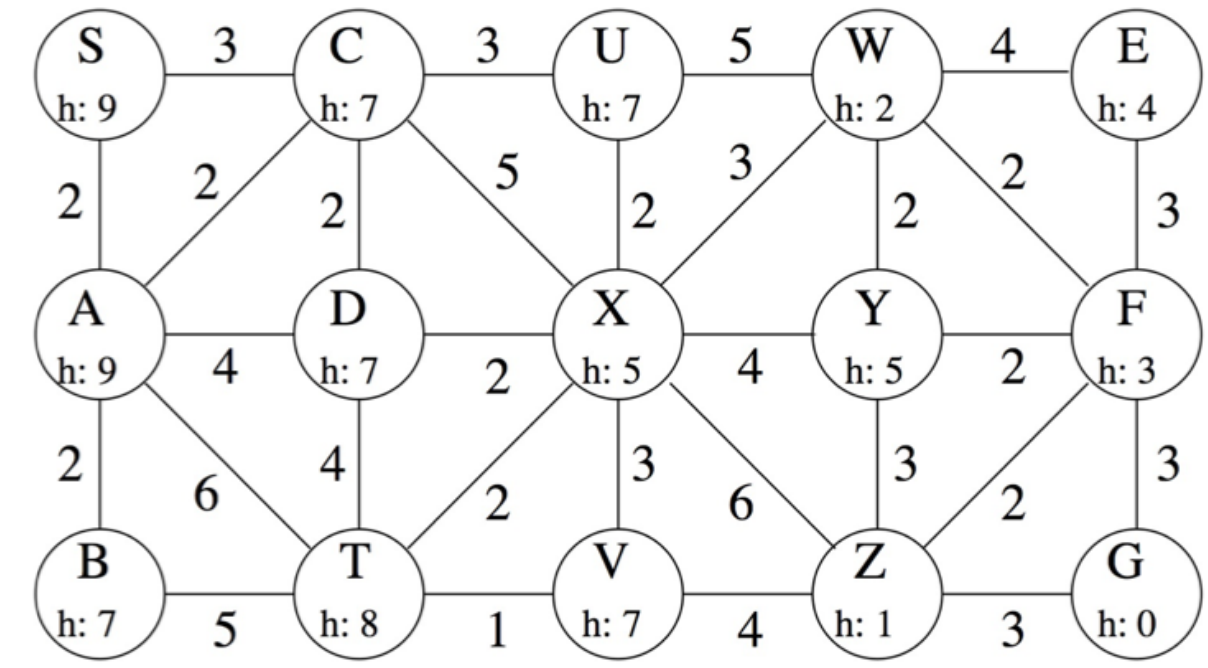

For each of the following strategies, list the order in which the states are expanded. Whenever there is a choice of states, you should select the one that comes first in alphabetical order. In each case, you should skip any states that have previously been expanded, and you should continue the search until the goal node is expanded.

(a) Breadth First Search

S, A, C, B, D, T, U, X, V, W, Y, Z, E, F, G

(b) Depth First Search

S, A, B, T, D, C, U, W, E, F, G

(c) Uniform Cost Search [Hint: first compute  $g()$  for each state in the graph]

S(0), A(2), C(3), B(4), D(5), U(6), X(7), T(8), V(9), W(10), Y(11), F(12), Z(13), E(14), G(15)

(d) Greedy Search, using the heuristic shown S, C, X, Z, G

(e) A\*Search, using the heuristic shown

S(9), C(10), A(11), B(11), D(12), X(12), W(12), U(13), Z(14), F(15), G(15)

Note that  $g(X)$  becomes 8 after C is expanded, but drops to 7 after D is expanded. Similarly,  $g(G)$  becomes 16 when Z is expanded, but drops to 15 after F is expanded.

## Question 4 - Relationships Between Search Strategies

Prove each of the following statements, or give a counterexample:

- (a) Breadth First Search is a special case of Uniform Cost Search  
Uniform Cost Search reduces to Breadth First Search when all edges have the same cost.
- (b) Breadth First Search, Depth First Search and Uniform Cost Search are special cases of best-first search.
- (c) Best-first search reduces to Breadth-First Search when  $f(n)$ =number of edges from start node to  $n$ , to UCS when  $f(n)=g(n)$ . It can be reduced to DFS by, for example, setting  $f(n)$ =-(number of nodes from start state to  $n$ ) (thus forcing deep nodes on the current branch to be searched before shallow nodes on other branches). Another way to produce DFS is to set  $f(n)=-g(n)$  (but this might produce a particularly bad choice of nodes within the DFS framework - for example, try tracing the order in which nodes are expanded when traveling from Urziceni to Craiova).
- (d) Uniform Cost Search is a special case of A\* Search
- (e) A\* Search reduces to UCS when the heuristic function is zero everywhere, i.e.  $h(n)=0$  for all  $n$ . This heuristic is clearly admissible since it always (grossly!) underestimates the distance remaining to reach the goal.

## Question 5 - Heuristic Path Algorithm

The *heuristic path algorithm* is a best-first search in which the objective function is

$$f(n) = (2 - w) \cdot g(n) + w \cdot h(n), \text{ where } 0 \leq w \leq 2$$

What kind of search does this perform when  $w=0$ ? when  $w=1$ ? when  $w=2$ ?

This algorithm reduces to Uniform Cost Search when  $w = 0$ , to A\* Search when  $w = 1$  and to Greedy Search when  $w = 2$ .

For what values of  $w$  is this algorithm complete? For what values of  $w$  is it optimal, assuming  $h()$  is admissible?

\*

It is guaranteed to be optimal when  $0 \leq w \leq 1$ , because it is equivalent to A Search using the heuristic:

$$f(n) = (2 - w) \cdot g(n) + w \cdot h(n)$$

When  $w > 1$  it is not guaranteed to be optimal (however, it might work very well in practice, for some problems).